

Interface Bonding With Corneal Crosslinking (CXL) After LASIK Ex Vivo

Theo G. Seiler,¹⁻³ Marleen Engler,¹ Eric Beck,¹ Reginald Birngruber,^{1,4} and Irene E. Kochevar¹

¹Wellman Center for Photomedicine-Massachusetts General Hospital, Harvard Medical School, Boston, Massachusetts, United States

²Universitätsklinik für Augenheilkunde, Inselspital, Bern, Switzerland

³The Institut für Refraktive und Ophthalmochirurgie (IROC), Zürich, Switzerland

⁴The Institut für Biomedizinische Optik, Universität zu Lübeck, Lübeck, Germany

Correspondence: Theo G. Seiler, Wellman Center for Photomedicine-Massachusetts General Hospital, Harvard Medical School, 50 Blossom Street, Boston, MA 02114, USA; gseiler@mgh.harvard.edu.

Submitted: June 13, 2017

Accepted: November 2, 2017

Citation: Seiler TG, Engler M, Beck E, Birngruber R, Kochevar IE. Interface bonding with corneal crosslinking (CXL) after LASIK ex vivo. *Invest Ophthalmol Vis Sci.* 2017;58:6292-6298. DOI:10.1167/iovs.17-22426

PURPOSE. Interface bonding with corneal crosslinking (CXL) after LASIK using two different photosensitizers was studied ex vivo.

METHODS. A LASIK flap was created in enucleated rabbit eyes using a femtosecond laser. After the dissection, CXL was performed to seal the interface. In one group interface CXL was performed using rose bengal and green light, whereas in a second group riboflavin and UV-A light was used. In both groups irradiance, radiant exposure, dye concentration, and imbibition time was varied. In a control group, LASIK only was performed. After the procedures, the maximal shear-force required to separate the flap from the stroma was measured. Additionally, corneal transmission spectra were recorded.

RESULTS. Optimized parameters for rose bengal/green-light bonding lead to a 2.1-fold increase in shear-force compared with untreated control eyes ($P < 0.01$). The optimal parameter combination was: irradiance of 180 mW/cm² for 14 minutes (total radiant exposure 150 J/cm²), rose bengal concentration 0.1%, and an imbibition time of 2 minutes. Optimized riboflavin/UV-A light parameters were 0.5% for 2 minutes with a radiant exposure of 8.1 J/cm² obtained by an irradiance of 30 mW/cm² for 4.5 minutes. These optimized parameters lead to a 2-fold increase compared with untreated control eyes ($P < 0.01$). Optical transmission experiments suggest safety for more posterior structures.

CONCLUSIONS. Based on ex-vivo results, interface bonding after LASIK using crosslinking with either rose bengal or riboflavin increases the adhesion between flap and stromal bed. In vivo trials are needed to evaluate the temporal evolution of the effect.

Keywords: LASIK, crosslinking, LASIK Xtra, cornea, CXL

LASIK has been used since the early nineties to correct refractive errors.¹ Due to the fast visual recovery and other advantages it has become the most frequently performed refractive surgery today.^{2,3} In 1998, the first case of iatrogenic keratectasia after LASIK was reported.⁴ In the following decade risk scores were evaluated by Randleman and coworkers⁵ to filter possible keratectasia candidates and avoid LASIK in such cases.

Parallel to the evolution of LASIK, a new technique was introduced experimentally in 1996 to stiffen corneal tissue by inducing crosslinks within the extracellular matrix (Seiler T, et al. *IOVS* 1996;37:ARVO Abstract 4671).^{6,7} After more than 10 years of clinical experience, it became evident that this procedure, called corneal crosslinking (CXL), is able to prevent the progression of keratectasia^{8,9} with a low rate of complications.¹⁰

During the past 3 years, combinations of these two techniques have been investigated for the prevention of post-LASIK ectasia and terms like LASIK Xtra¹¹ or SCXL¹² were coined. However, treatment parameters used were not based on experimental data and efficacy could not be demonstrated because of the low prevalence of iatrogenic keratectasia. Also, a variety of CXL-parameter combinations are already used clinically. One study¹² reported two cases after SCXL needing

retreatment, however, the flap could not be relifted at 1 year after surgery indicating a strong bonding effect between flap and stroma.

This bonding effect serves as motivation for an experimental study to test the hypotheses that an immediate bonding is produced between LASIK flap and stroma by CXL and that optimized parameter conditions using either riboflavin or rose bengal can be identified.¹³ The identification of these optimized parameters is also necessary for a subsequent in vivo study to investigate the bonding effect over time.

MATERIALS AND METHODS

Cornea Preparation and Flap Dissection

Adult New Zealand White fresh frozen rabbit eyes (Pel-Freez Biologicals, Roger, AR, USA) were thawed in air. The epithelium was removed using a blunt hockey knife in order to standardize the starting condition. Corneoscleral disks were excised and placed in a 15% dextran wt/wt aqueous solution (Sigma-Aldrich Corp., St. Louis, MO, USA) for up to 60 minutes until physiological hydration was obtained, determined by the central corneal thickness of $350 \pm 30 \mu\text{m}$.¹⁴ Central corneal pachymetry was measured by an ultrasound pachymeter (SP-



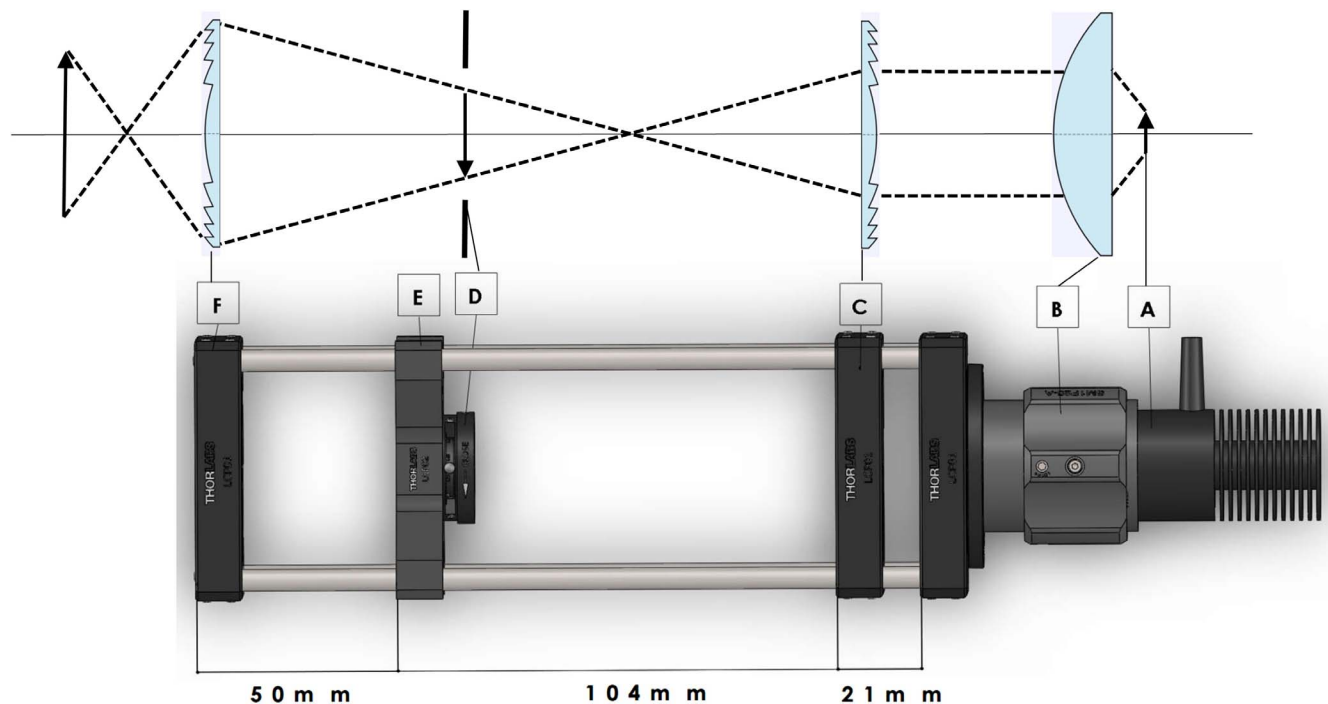

FIGURE 1. Irradiation delivery system for green light. The light is emitted by the LED (A) and was collimated using a plano-convex lens ($f = 20.4$ mm) (B). A Fresnel lens ($f = 51$ mm) (C) forms an intermediate image where an iris aperture (D) was included followed by a short pass filter at 600 nm (E). Final imaging on the cornea was performed by a second Fresnel lens ($f = 32$ mm) (F).

100; Tomey, Nagoya, Japan) to ensure the steady state of the corneal hydration ($<20 \mu\text{m}$ change in 3 consecutive measurements 5 minutes apart). The LASIK flaps were created using the Femto LDV model Z6 (Ziemer Ophthalmic Systems, Port, Switzerland). For the femtosecond laser dissection, corneas were mounted into an artificial anterior chamber (Ziemer Ophthalmic Systems) with an IOP equivalent of 20 mm Hg with a solution of 15% dextran. The handheld laser delivery head was attached onto the artificial anterior chamber. After contact between the laser head and the corneal surface was reached, the flap dissection procedure was performed. The flap dimensions were: diameter of 9.0 mm, a thickness of 90 μm , and a hinge height of 0.3 mm resulting in a width of 3.2 mm. The side cut was performed with 90° to the applanation. The femtosecond laser parameters were set for the stroma to an energy level of 100% and a velocity of 10 mm/s, for the side-cut the energy level was set to 130%.

Photobonding of the Flap With Rose Bengal and Green Light

After lifting the flap, rose bengal (Sigma-Aldrich Corp.) was applied onto the stroma bed for 60 or 120 seconds. After the imbibition, the stroma was wiped dry using a sponge (K-Sponge II; Katena Products, Denville, NJ, USA) and the flap was repositioned. Green light obtained from a high-power light-emitting diode (LED; Thor Labs, Newton, NJ, USA) was focused onto the cornea using a self-built light delivery device (Fig. 1) with an irradiance of $180 \text{ mW}/\text{cm}^2$. The LED spectrum peaked between 530 and 550 nm. The spatial profile generated on the cornea had a top hat shape with a radiant intensity of 90% at 3.5-mm eccentricity compared with the center of the profile. The following crosslinking parameters for rose bengal were selected according to previous experiments^{13,14}: concentrations of 0.02%, 0.1%, and 0.5% wt/wt in PBS, radiant exposures of 50, 100, and 150 J/cm^2 , and imbibition time of 1 or 2

minutes. We considered a 25% difference in the means between results of treatments to be significant. A standard deviation of 20% was used (based on previous similar measurements), $P < 0.05$ and 80% power. According to the calculated sample size and the selected combinations of treatment parameters a total of 77 corneas, including the control group, were used. Throughout the entire crosslinking procedure, the cornea was misted with PBS every 180 seconds to prevent corneal drying.

Photobonding of the Flap With Riboflavin and UV-A Light

Similar to the rose bengal experiments, the stromal bed was imbibed with riboflavin-5-monophosphate (Sigma-Aldrich Corp.) in PBS. UV-A light was generated by the Food and Drug Administration-approved KXL-System (Avedro, Inc., Waltham, MA, USA), which uses narrow band UV diodes emitting at 365 ± 5 nm. The spatial profile generated on the cornea had a Gaussian shape with a radiant intensity of around 60% at 3.5-mm eccentricity compared with the center of the profile. The crosslinking parameters were based on clinical proposals published^{11,12}: riboflavin concentration (0.02%, 0.1%, and 0.5% wt/wt in PBS), radiant exposure (2.7, 5.4, and 8.1 J/cm^2), irradiance (9, 18, and 30 mW/cm^2), and imbibition time (1 or 2 minutes). We considered a 25% difference in the means between results of treatments to be significant. A standard deviation of 20% was used (based on previous similar measurements), $P < 0.05$ and 80% power. According to the calculated sample size and the selected combinations of treatment parameters a total of 84 corneas, including the control group, were used. Throughout the entire crosslinking procedure, the cornea surface was misted with PBS every 180 seconds to prevent corneal drying.

All experiments were performed at 19°C . Control groups were either treated with dye only (no irradiation) or with PBS

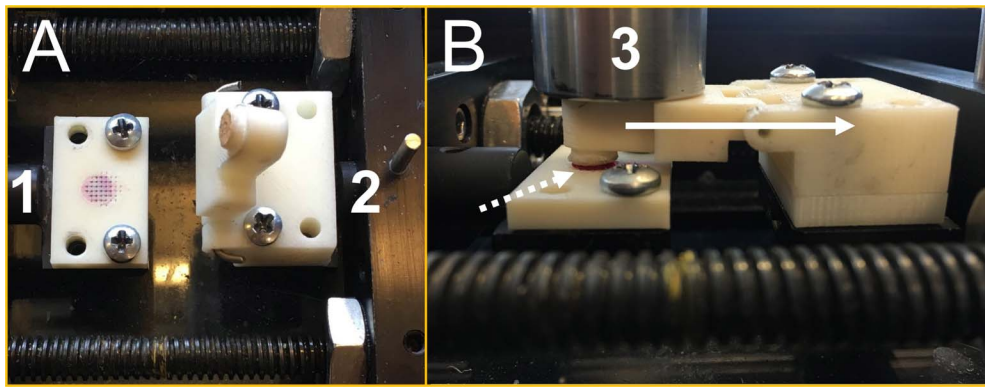

FIGURE 2. Modified uniaxial tensiometer. (A) A self-built sample holder mounted onto the left jaw, which is connected to the load cell (1), and a modified holder on the right jaw that is connected to the motor (2). (B) The bonded and untreated stroma and flap are placed on the left holder, the rounded part of the right holder is placed over the sample, (dashed arrow) and a 100-g weight is placed on top (3). The solid white arrow shows the pulling direction of the motor-connected jaw.

only (no dye), and then exposed to either green light or UV-A irradiation.

Detection of Adhesion

For measurement of the adhesion between the stroma and the flap a 7-mm central disk was punched out of the corneal sample (Donor Cornea Punch; Katena Products, Denville, NJ, USA). Prior to the shear measurement, central corneal thickness was again measured. Specimens with a difference of more than 30 μm compared with the thickness prior to the LASIK flap creation were discarded. The remaining disks were then mounted between modified jaws of a commercially available tensiometer (eXpert 4000; Admet, Norwood, MA, USA). The setup is depicted in Figure 2. The posterior stromal layer of each sample was mounted onto a needle cushion. The needle cushion consisted of 30-G needle tips glued into perforated plastic, shown in Figure 2A. It was mounted on the jaw of the tensiometer that is connected to the load cell. The other jaw, connected to the motor, was attached to the flap side of the corneal sample. To guarantee similar conditions for each measurement, a 100-g weight was placed on top of setup (Fig. 2B). After mounting, the jaw connected to the motor was pulled with a speed of 10 mm/min. The loadcell connected to the left jaw detected the force [mN] each 10 ms during the measurement cycle. After the measurement, the specimen was visually inspected under a microscope to assure a proper separation of flap and stroma. The data acquired were exported and evaluated using MS Excel (Microsoft, Redmond, WA, USA). Maximal forces needed to separate flaps from stroma in different groups were compared using ANOVA. The problem of multiple comparisons was considered using the least significant difference (LSD) correction (Winstat, R. Finch, Germany). Statistical significance was accepted if $P < 0.05$.

Optical Transmission Measurements of Corneal Tissue

To estimate the safety for more posterior structures light transmission measurements were carried out. Transmissions were investigated using a Cary 300 Scan UV-Visible spectrophotometer with an integrating sphere (Aligent Technologies, Santa Clara, CA, USA) for all relevant groups obtained from the adhesion experiments ($n = 3$). First, a baseline value was recorded using the 1-mm thick quartz glass sample holder.

Then a baseline-corrected transmission spectrum of the entire cornea was acquired and evaluated using MS Excel.

RESULTS

Adhesion Between Stroma and Flap

Figure 3 depicts two typical shear force-displacement curves: in crosslinked samples (red line) phase A shows a nonlinear increase in force until a maximum is reached and separation of flap and stroma begins. After reaching the maximal shear force the flap begins to separate, labeled as phase B in Figure 3. When separation is completed, the sample exhibits dynamic friction (phase C). In contrast, in nonbonded controls (blue line) a different behavior is observed with a gradual increase in shear force with a maximum leading to a smooth transition into dynamic friction.

The maximal shear force needed to separate the flap from the stroma for all the groups is shown in Figures 4 and 5. Either with rose bengal or with riboflavin, the optimized parameters lead to an enhancement in maximum shear-force by a factor of approximately 2 compared with the control group.

For riboflavin, all flap-bonded groups show an adhesion significantly stronger than the control group ($P < 0.05$), except for 0.02% riboflavin ($P = 0.33$). The imbibition time, 1 versus 2 minutes, did not significantly influence adhesion (Fig. 4A). Increasing the radiant exposure, using an irradiance of 9 mW/cm², lead to a significantly enhanced adhesion in the riboflavin group reaching a maximum at 8.1 J/cm² (control versus 2.7 J/cm² [$P = 0.013$], control versus 5.4 J/cm² [$P = 0.013$], 5.4 J/cm² versus 8.1 J/cm² [$P = 0.037$]; Fig. 4B). No significant difference between different irradiances (9, 18, and 30 mW/cm²) was detected at a radiant exposure of 8.1 J/cm².

For rose bengal, all concentrations tested led to a significant bonding effect ($P < 0.05$) as illustrated in Figure 5. Longer imbibition time did not differ from the shorter one (Fig. 5A). A trend toward greater maximal shear force with higher radiant exposures was identified (versus control, 50 J/cm² [$P = 0.031$], 100 J/cm² [$P = 0.007$], 150 J/cm² [$P = 0.004$], 50 vs. 150 J/cm² [$P = 0.037$]; Fig. 5B). Using a lower irradiance of 120 mW/cm² did not result in a different bonding strength compared with 180 mW/cm².

Optical Transmission

The transmissions of flap-bonded corneas are illustrated in the Table. All investigated groups used an imbibition time of 2

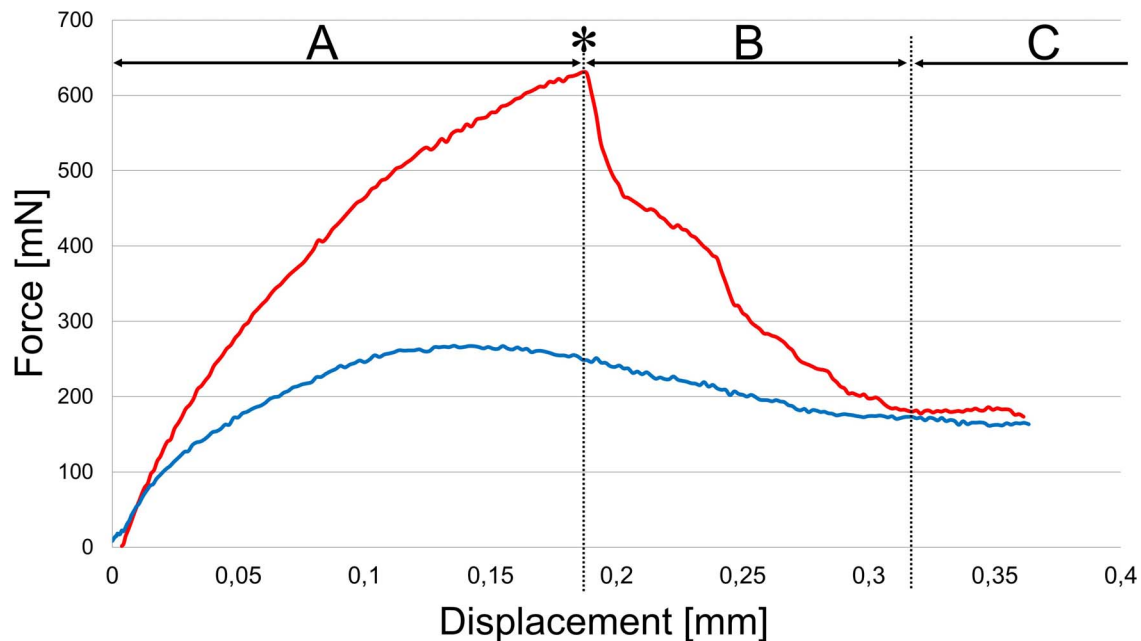

FIGURE 3. Typical nonlinear stress behavior for interface-bonded LASIK corneas (*red*) and nontreated LASIK corneas (*blue*). The maximal force reached before separation of the stroma and flap is indicated by an *asterisk*. Phase A describes the nonlinear response that is induced by the applied tension. Phase B describes the separation episode, and in phase C an equilibrium is reached that is known as the dynamic friction.

minutes with the listed concentrations. Higher concentrations lead to a lower transmission.

DISCUSSION

The main findings of this study are as follows: (1) the combination of CXL and LASIK results in enhanced adhesion compared with untreated LASIK corneas, due to bonding between flap and stroma; (2) optimized parameters for rose bengal/green light achieve flap bonding equivalent to riboflavin/UV-A light flap bonding. Rose bengal 0.1% with an imbibition time of 2 minutes followed by an irradiation 150 J/cm² at 180 mW/cm² was chosen, whereas for riboflavin 0.5% for 2 minutes with an irradiance of 30 mW/cm² and a radiant exposure of 8.1 J/cm² was identified to give maximum adhesion; (3) the bonding strength is not dependent on irradiance, but increases with the amount of light (radiant exposure) supplied to the interface for crosslinking; and (4) transmission experiments suggest safety for more posterior structures.

The principle of bonding collagen tissue by inducing crosslinks has been investigated previously.^{15–17} Photoactivated dye generates reactive species, including singlet oxygen, that initiate covalent protein–protein crosslinking by oxidizing amino acid side chains.^{15–17} For crosslinked corneal tissue, Hayes et al.¹⁸ showed by means of x-ray scattering that the crosslinks are located within the collagen fibril, on the fibril surface as well as in the interfibrillar space. Those interfibrillar crosslinks connect neighboring proteoglycans and such crosslinks may explain the newly formed connections between LASIK flap and stroma.

This is not the first approach to bond the flap to the stroma: in 2011, Mi and colleagues¹⁹ investigated methods to increase flap adhesion in LASIK-treated bovine corneas. Besides the application of activated stromal fibroblasts or interleukins, they also investigated the effect of riboflavin/UV-A crosslinking after LASIK. Although using a different experimental design (200 μm flap, 0.1% riboflavin application to the surface of the entire

cornea, peel test instead of shear measurement) they found that adhesion increased by a factor of 2, surprisingly very similar to the increase in shear force measured here. Another study²⁰ investigated the combination of fibrinogen, riboflavin, and UV-A light to bond two corneas together. Using this approach, a maximal increase in adhesion of a factor of 5 was found.

The results of our measurements of the shear-force required to separate flap and stroma confirm experimentally a previous clinical observation¹² of increased bonding of flap and wound bed after riboflavin/UV-A CXL.

Interface bonding by CXL after LASIK was achieved by either rose bengal/green light or riboflavin/UV-A light treatment. The potential advantage of faster keratocyte recovery in rose bengal/green-light crosslinking²¹ stands in contrast to generally longer light application times and probably more intraoperative glare compared with riboflavin/UV-A CXL. The optimized parameters identified in this study for LASIK combined with riboflavin CXL suggest that the clinically used protocols^{11,12} are by far not optimized, and that an increase in shear-force by a factor of 2 over non-CXL treatment is possible. On the other hand, it remains unclear how much CXL is needed to compensate for the weakening induced by LASIK. Recently, it was found that human corneas are weakened by only approximately 10% following creation of a 90-μm flap.²² The need for optimization of the CXL-treatment after LASIK is supported by a very recent case report²³ describing a postoperative ectasia after LASIK Xtra. The eye was treated using 0.22% riboflavin for 90 seconds and after rinsing of the interface a radiant exposure of only 2.7 J/cm² was applied. In addition, the ectasia was noticed later than 1 year after treatment.

Irradiance seems not to influence the result when using 9, 18, and 30 mW/cm² in the riboflavin groups, indicating that Bunsen-Roscoe's law is valid for planar interface CXL. This stands in contrast to volume CXL for tissue stiffening, where Bunsen-Roscoe's law is known to be invalid.²⁴ A possible explanation might be the negligible oxygen diffusion into a depth of 100 μm²⁵ during a continuous irradiation. Thus, the

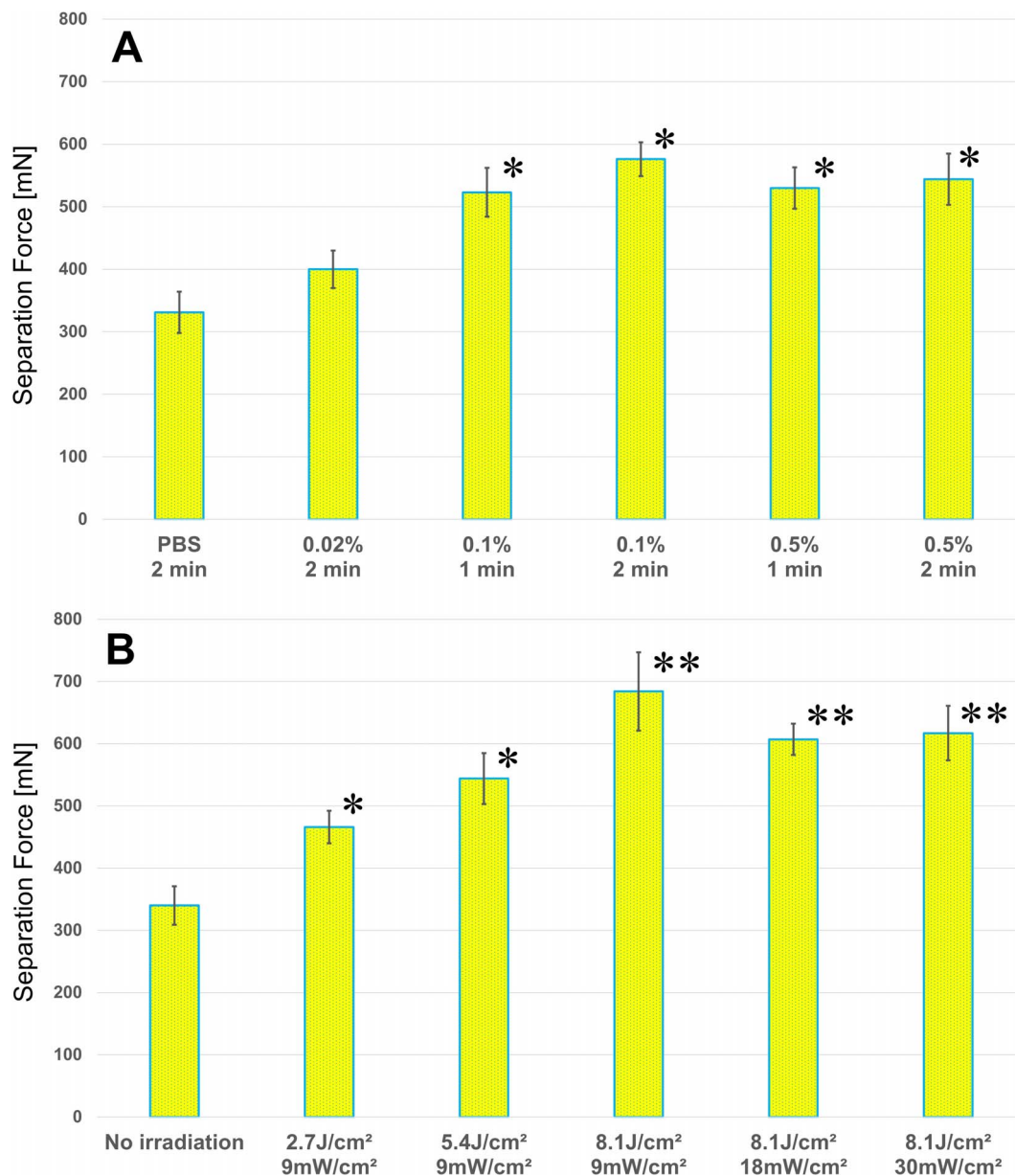

FIGURE 4. Maximal shear force needed for separation of photobonded LASIK flap from stroma using riboflavin and UV-A. **(A)** Riboflavin concentration and imbibition times were varied. Irradiance used was 9 mW/cm² with a radiant exposure of 5.4 J/cm². Significant differences ($P < 0.05$) compared with the PBS control are indicated with an *asterisk*. **(B)** Radiant exposure and irradiance were varied using 0.5% riboflavin with an imbibition time of 2 minutes. Significant differences ($P < 0.05$) between an experimental group and the no irradiation control are marked with an *asterisk*. *Double asterisks* indicate significant differences versus 5.4 J/cm².

clinically anticipated reduced efficacy of CXL with higher irradiances and shorter treatment times due to lower oxygen availability has no impact here. In addition, shorter treatment times with higher irradiances allow less diffusion of the photosensitizer from the stroma into the flap²⁶ and consecutively more light is transmitted to the interface to induce more crosslinks there.

In contrast, the applied total energy (radiant exposure) is related to the bonding effect. Thus, more new bonds are created when using higher radiant exposures. The similar maximal increase with both used dyes suggests a possible upper limit of induced crosslinks between flap and stroma.

The fraction of the incident light that is transmitted through the cornea is different for rose bengal and riboflavin. In rose bengal-treated corneas both concentrations examined suggest

safety for more posterior structures of the eye. We have chosen 0.1% as the optimal concentration in order to use the lowest concentration necessary. For riboflavin-treated corneas, 0.5% and 0.1% concentrations produced the same bonding strength. However, we selected 0.5% as the optimal concentration because the total corneal transmission is lower and more UV-A light can be absorbed within the cornea creating further stromal crosslinks.²⁷

A limitation of this study is the use of ex vivo rabbit eyes because only the immediate effect can be studied. Clinical studies^{12,28} have shown that the transition zones adjacent to the interface showed morphologic changes for several months indicating a healing response that may modulate the biomechanical effect. Consequently, further investigations in vivo must be carried out for the evaluation of safety and efficacy of

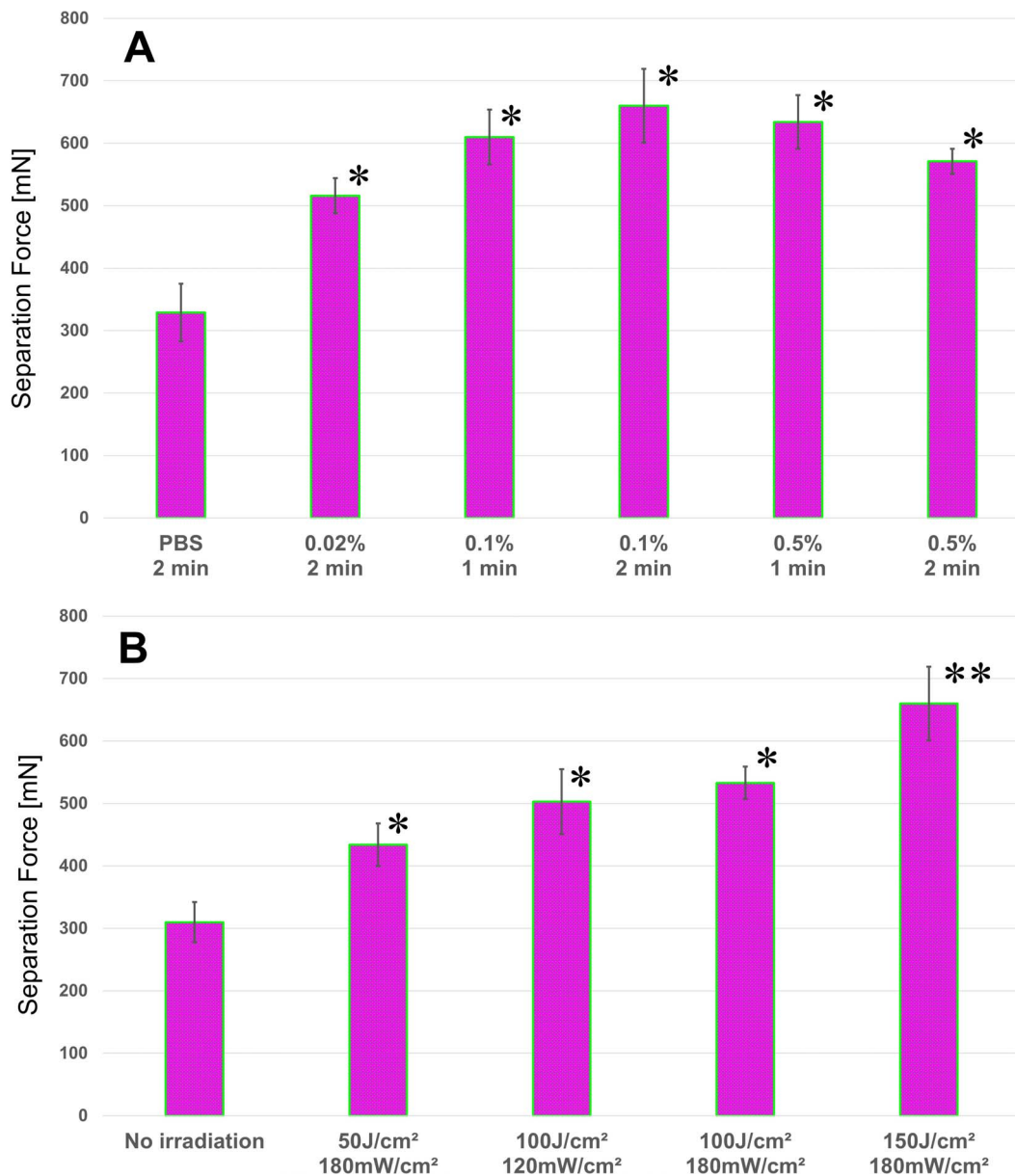

FIGURE 5. Maximal shear force needed for separation of photobonded LASIK flap from stroma using rose bengal and green light. **(A)** Rose bengal concentration and imbibition times were varied. Irradiance used was 180 mW/cm² with a radiant exposure of 150 J/cm². Significant differences ($P < 0.05$) compared with the PBS control are indicated with an *asterisk*. **(B)** Radiant exposure and irradiance were varied using 0.1% rose bengal with an imbibition time of 2 minutes. Significant differences ($P < 0.05$) between an experimental group and the no irradiation control are marked with an *asterisk*. *Double asterisks* indicate significant differences versus 50 J/cm².

both procedures, in particular to document endothelial integrity. In such studies, the ablation of the stroma with an excimer laser should be included as well as a possible increase of the applied energy by 20% to compensate for epithelial absorption should be considered.

In summary, the results of this study quantitatively demonstrate CXL-initiated bonding of LASIK flaps. In vivo

trials in rabbits are needed to evaluate a possible further enhancement of flap bonding during the healing phase as the immediate effect alone does not sufficiently explain the inability to relift the flap after a year.¹² These future studies may also indicate whether the increased stiffening and the flap bonding may compensate for weakening of the cornea induced by LASIK.

TABLE. Transmission Values for Rose Bengal Crosslinked Corneas Measured at 550 nm and for Riboflavin Crosslinked Corneas at 365 nm

	0.1% Rose Bengal	0.5% Rose Bengal	0.1% Riboflavin	0.5% Riboflavin
Transmission at 550 nm	3%	<1%	-	-
Transmission at 365 nm	-	-	60%	17%

All evaluated groups had an imbibition time of 2 minutes with the listed concentrations.

Acknowledgments

The authors thank Ziemer Ophthalmic Systems (Port, Switzerland) for the allocation of the Ziemer LDV Z6 femtosecond laser, and in particular, Sandra Etter and Sarah Moyle, PhD, for the support during the experiments. The authors also thank Avedro, Inc. (Waltham, MA, USA) for the allocation of the KXL light source. In addition, they thank Theo Seiler Senior, William Farinelli, and Joe Musacchia for the inspiring discussions and their support during the experiments.

Supported by an unrestricted grant from the Swiss National Science Foundation (TGS; Berne, Switzerland).

Disclosure: **T.G. Seiler**, None; **M. Engler**, None; **E. Beck**, None; **R. Birngruber**, None; **I.E. Kochevar**, None

References

- Pallikaris IG, Papatzanaki ME, Siganos DS, Tsilimbaris MK. A corneal flap technique for laser in situ keratomileusis. *Human studies. Arch Ophthalmol.* 1991;109:1699-702.
- Sugar A, Rapuano CJ, Culbertson WW, et al. Laser in situ keratomileusis for myopia and astigmatism: safety and efficacy. A report by the American Academy of Ophthalmology. *Ophthalmology.* 2002;109:175-187.
- Mitka M. FDA focuses on quality-of-life issues for patients following LASIK surgery. *JAMA.* 2009;302:2420-2422.
- Seiler T, Quirke AW. Iatrogenic keratectasia after LASIK in a case of forme fruste keratoconus. *J Cataract Refract Surg.* 1998;24:1007-1009.
- Randleman JB, Woodward M, Lynn MJ, Stulting RD. Risk assessment for ectasia after corneal refractive surgery. *Ophthalmology.* 2008;115:37-50.
- Spoerl E, Huhle M, Kasper M, Seiler T. Artificial stiffening of the cornea by induction of intrastromal cross-links. *Ophthalmologie.* 1997;94:902-906
- Wollensak G, Spoerl E, Seiler T. Riboflavin/ultraviolet-a-induced collagen crosslinking for the treatment of keratoconus. *Am J Ophthalmol.* 2003;135:620-627.
- Raiskup F, Theuring A, Pillunat LE, Spoerl E. Corneal collagen crosslinking with riboflavin and ultraviolet-A light in progressive keratoconus: ten-year results. *J Cataract Refract Surg.* 2015;41:41-46.
- Hafezi F, Kanellopoulos J, Wiltfang R, Seiler T. Corneal collagen crosslinking with riboflavin and ultraviolet A to treat induced keratectasia after laser in situ keratomileusis. *J Cataract Refract Surg.* 2007;33:2035-2040.
- Seiler TG, Schmidinger G, Fischinger I, Koller T, Seiler T. Komplikationen der Vernetzung der Hornhaut. *Ophthalmologie.* 2013;110:639-644.
- Kanellopoulos AJ, Pamel GJ. Review of current indications for combined very high fluence collagen cross-linking and laser in situ keratomileusis surgery. *Indian J Ophthalmol.* 2013;61:430-432.
- Seiler TG, Fischinger I, Koller T, Derhartunian V, Seiler T. Superficial corneal crosslinking during laser in situ keratomileusis. *J Cataract Refract Surg.* 2015;41:2165-2170.
- Cherfan D, Verter EE, Melki S, et al. Collagen cross-linking using rose bengal and green light to increase corneal stiffness. *Invest Ophthalmol Vis Sci.* 2013;54:3426-3433.
- Riau AK, Tan NY, Angunawela RI, et al. Reproducibility and age-related changes of ocular parametric measurements in rabbits. *BMC Vet Res.* 2012;8:138.
- Verter EE, Gisel TE, Yang P, Johnson AJ, Redmond RW, Kochevar IE. Light-initiated bonding of amniotic membrane to cornea. *Invest Ophthalmol Vis Sci.* 2011;52:9470-9477.
- Verweij H, Van Steveninck J. Model studies on photodynamic crosslinking. *Photochem Photobiol.* 1982;35:265-267.
- Kochevar IE, Redmond RW. Photosensitized production of singlet oxygen. *Methods Enzymol.* 2000;319:20-28.
- Hayes S, Kamma-Lorger CS, Boote C, et al. The effect of riboflavin/UVA collagen cross-linking therapy on the structure and hydrodynamic behaviour of the ungulate and rabbit corneal stroma. *PLoS One.* 2013;8:e52860.
- Mi S, Dooley EP, Albon J, Boulton ME, Meek KM, Kamma-Lorger CS. Adhesion of laser in situ keratomileusis-like flaps in the cornea: effects of crosslinking, stromal fibroblasts, and cytokine treatment. *J Cataract Refract Surg.* 2011;37:166-172.
- Littlechild SL, Brummer G, Zhang Y, Conrad GW. Fibrinogen, riboflavin, and UVA to immobilize a corneal flap-conditions for tissue adhesion. *Invest Ophthalmol Vis Sci.* 2012;53:4011-4020.
- Zhu H, Alt C, Webb RH, Melki S, Kochevar IE. Corneal crosslinking with rose bengal and green light: efficacy and safety evaluation. *Cornea.* 2016;35:1234-1241.
- Knox Cartwright NE, Tyrer JR, Jaycock PD, Marshall J. Effects of variation in depth and side cut angulations in LASIK and thin-flap LASIK using a femtosecond laser: a biomechanical study. *J Refract Surg.* 2012;28:419-425.
- Taneri S, Kiessler S, Rost A, Dick HB. Corneal ectasia after LASIK combined with prophylactic corneal cross-linking. *J Refract Surg.* 2017;33:50-52.
- Hammer A, Richoz O, Arba Mosquera S, Tabibian D, Hoogewoud F, Hafezi F. Corneal biomechanical properties at different corneal cross-linking (CXL) irradiances. *Invest Ophthalmol Vis Sci.* 2014;55:2881-2884.
- Kamaev P, Friedman MD, Sherr E, Muller D. Photochemical kinetics of corneal cross-linking with riboflavin. *Invest Ophthalmol Vis Sci.* 2012;53:2360-2367.
- Ehmke T, Seiler TG, Fischinger I, Ripken T, Heisterkamp A, Frueh BE. Comparison of corneal riboflavin gradients using dextran and HPMC solutions. *J Refract Surg.* 2016;32:798-802.
- Kanellopoulos AJ, Asimellis G, Salvador-Culla B, Chodosh J, Ciolino JB. High-irradiance CXL combined with myopic LASIK: flap and residual stroma biomechanical properties studied ex-vivo. *Br J Ophthalmol.* 2015;99:870-874.
- Tomita M, Yoshida Y, Yamamoto Y, Mita M, Waring G IV. In vivo confocal laser microscopy of morphologic changes after simultaneous LASIK and accelerated collagen crosslinking for myopia: one-year results. *J Cataract Refract Surg.* 2014;40:981-990.