



Brief exposures to conspecific-derived alarm substance are sufficient to induce paternal intergenerational effects in zebrafish

James Ord · Alireza Fazeli · Penelope J. Watt

Received: 13 July 2021 / Accepted: 12 June 2022 / Published online: 22 June 2022
© The Author(s) 2022

Abstract Paternal intergenerational effects, whereby the father's environment influences the phenotype of the offspring via molecular (e.g. epigenetic) changes to the sperm, comprise an area of active research in multiple biological contexts. Spermatogenesis is a critical window of sensitivity to environmental changes, such that males at full sexual maturity can acquire, incorporate, and transmit environmental information in spermatozoa. The degree of sensitivity is less clear, and as such previous experimental studies have typically relied on prolonged exposure regimes encapsulating the entire period of spermatogenesis. Here we exposed adult male zebrafish to a model stressor (conspecific-derived alarm substance, AS) in two 20-min episodes timed

either shortly before or during the onset of spermatogenesis. There was no clear effect of paternal stress on a behavioural stress response in larval offspring but clear reductions in anxiety-like behaviour in juvenile offspring. Our findings suggest that prolonged exposures may not be required for the induction of measurable intergenerational responses in this popular vertebrate model.

Keywords Zebrafish · Paternal effects · Intergenerational effects · Stress · Thigmotaxis

Introduction

Paternal intergenerational effects have garnered increasing attention in recent years in contexts such as human epidemiology (Donkin et al. 2016), livestock

Supplementary Information The online version contains supplementary material available at <https://doi.org/10.1007/s10641-022-01289-7>.

J. Ord
Institute of Fish and Wildlife Health, University of Bern,
Länggassstrasse 122, 3012 Bern, Switzerland

J. Ord (✉) · P. J. Watt
Department of Animal and Plant Sciences, University
of Sheffield, Alfred Denny Building, Western Bank,
Sheffield S10 2TN, UK
e-mail: jms.ord18@gmail.com

A. Fazeli
Department of Pathophysiology, Institute of Biomedicine
and Translational Medicine, University of Tartu, Ravila
14b, 50411 Tartu, Estonia

A. Fazeli
Academic Unit of Reproductive and Developmental
Medicine, Department of Oncology and Metabolism,
University of Sheffield, Level 4, Jessop Wing, Tree Root
Walk, Sheffield S10 2SF, UK

A. Fazeli
Institute of Veterinary Medicine and Animal Sciences,
Estonian University of Life Sciences, Kreutzwaldi 62,
51006 Tartu, Estonia

breeding (Sellem et al. 2020), and evolutionary biology (Macartney et al. 2018). Information additional to the genome (e.g. epigenetic modifications and non-coding RNA) is transmitted in the sperm, is responsive to the environment, and has a non-trivial bearing on offspring phenotype (Chen et al. 2016). As a result, paternal experiences (e.g. stress and diet) leave an imprint on the offspring phenotype, including behaviour. While most empirical data have been garnered from rodent (Rodgers et al. 2013; Watkins and Sinclair 2014; Gapp et al. 2018) and invertebrate models (Klosin et al. 2017), such paternal environmental effects have only recently begun to be observed more broadly among vertebrates, for instance in fish. Paternal effects in fish have been observed at both phenotypic and molecular levels, including effects of toxicants (Carvan et al. 2017), rearing environment (Rodriguez Barreto et al. 2019), hypoxia (Wang et al. 2016), and stress (Ord et al. 2020). Paternal effects of stress in zebrafish are reminiscent of those in rodent models reflecting disruption to physiological stress response pathways (Ord et al. 2020). Collectively, the experimental data suggest not only that sperm transmit molecular information that is dependent on the environment that produced them, but that such paternal intergenerational mechanisms are taxonomically widespread.

Exposure to an altered environment throughout the parental generation is not a prerequisite for paternal intergenerational effects, as phenotypic changes in the offspring can be induced following exposures encompassing the period of spermatogenesis in adult male mice (Rodgers et al. 2013). Paternal stress models in both rodents (Rodgers et al. 2013; Watkins and Sinclair 2014) and fish (Zajitschek et al. 2014; Ord et al. 2020) have previously been designed such that the period of environmental manipulation encapsulates the entire spermatogenic cycle or longer. While potentially increasing the opportunity for the experiment to capture an intergenerational effect mechanism, such exposure regimes must necessarily be prolonged in order to encompass the entire period (e.g. typically 35 days in mice; Oakberg 1956). Spermatogenesis, however, is a highly complex process in which cells undergo intense morphological changes and extensive chromatin remodelling during their differentiation from spermatogonial stem cells to mature sperm (Zamudio et al. 2008). The idea that different periods within or around spermatogenesis

may be differentially susceptible to acquiring heritable changes has not received attention until relatively recently. In mice, the molecular composition of spermatozoa has been shown to be liable to alteration during the final stage of maturation in the mammalian epididymis (Sharma et al. 2018).

In zebrafish, spermatogenesis is rapid compared to other vertebrates, lasting just 6 days from the onset of meiosis until differentiation into mature spermatozoa (Leal et al. 2009). The molecular regulation of zebrafish spermatogenesis is responsive to cortisol, the principal stress hormone in zebrafish (Tovo-Neto et al. 2020). We therefore hypothesised that germ cells could acquire stress-induced epigenetic changes prior to differentiation in mature sperm, leading to phenotypic alterations in the offspring. We tested whether such alterations could be induced by brief exposures to a natural stressor, conspecific-derived alarm substance (AS) in the paternal generation, timed around the period of spermatogenesis. The exposures, comprising two 20-min periods on 2 consecutive days, can be considered brief compared to the prolonged exposure periods used in previous studies (e.g. Rodgers et al. 2013; Ord et al. 2020). Specifically, we tested the effects on the offspring of exposure to AS during two different time windows around spermatogenesis. Males were exposed during different periods prior to mating, corresponding with a period either before or during the onset of the predicted spermatogenic cycle, respectively. On days 13 and 12 prior to mating (pre-spermatogenesis alarm substance, PSAS), the sperm that would eventually be used for fertilisation would still be in the mitotic or proliferative stage as spermatogonia. These spermatogonia may be undifferentiated, or they may have begun differentiation towards spermatocytes. On days 6 and 5 prior to mating (onset-spermatogenesis alarm substance, OSAS), the sperm that would eventually be used for fertilisation would likely be in the spermatocyte stage, in which they have begun meiosis and subsequent differentiation into spermatozoa (here, we consider ‘spermatogenesis’ to commence from the onset of meiosis; Leal et al. 2009). Therefore, alterations in the progeny induced following paternal exposure in these distinct time windows may reflect disruption to spermatogonia and spermatocytes, respectively. It is plausible that disruption in the earlier window may be less likely to induce paternal effects, given that any disruption to the epigenetic

state could be diluted or counteracted through mitotic proliferation of the spermatogonia (Leal et al. 2009).

To test for the effects of paternal stress on the offspring, we used larval thigmotaxis in response to AS as a model behavioural stress response liable to suppression following paternal chronic stress (Ord et al. 2020). To examine the longer lasting influences of paternal AS exposure, we further tested individual juvenile offspring for differences in anxiety-like behaviour in the form of thigmotaxis (Stewart et al. 2012). We predicted that paternal stress treatments would induce phenotypic changes consistent with disruption to stress response pathways, specifically suppression of AS-induced thigmotaxis in the larvae and reduction in thigmotaxis in individual juveniles.

Methods

Animals and housing

A total of 60 adult male London wildtype (LWT) zebrafish were selected from healthy stock, reared in tanks on a flow-through system with water heated to 26 °C and kept on a 12:12-h light/dark cycle. Animals were fed with live brine shrimp or flake food twice daily.

Alarm substance (AS) extraction

Alarm substance (AS) was derived from mature zebrafish (indiscriminate of sex), using a modified version of a method described by Egan et al. (2009). For every 2 ml of extract, five fish were euthanised, and 7–10 lacerations were made to the epidermis on both sides of each fish. All five fish were then placed in a single 50 ml tube with 2 ml water and gently shaken. The water containing the extract was then eluted, incubated at 95 °C for 16 h, centrifuged to remove debris, and filtered through a microfilter.

Experimental treatments

Fish were housed together in groups of five per 10-l tank for at least 1 week prior to experimental treatment, and each group of five was assigned randomly to one of three experimental groups: a handled control group (CT), a treatment group exposed to AS on days 13 and 12 prior to mating (pre-spermatogenesis alarm

substance, PSAS), and a treatment group exposed to AS on days 6 and 5 prior to mating, the predicted onset of the spermatogenic cycle (onset-spermatogenesis alarm substance, OSAS).

Animals were transferred to tanks (19×12×12 cm) and exposed to AS in the same groups of five in which they were housed. For each exposure, 0.5 ml of AS was administered to 2 L fresh aquarium water containing the fish, following a 20-min acclimation period. After 20 min of exposure, fish were moved to a second tank containing 2 L fresh aquarium water for 5 min to remove traces of AS before returning them to the recirculatory system. Any groups not undergoing AS treatment at a given time point (or at all in the case of CT fish) were moved to holding tanks identical to the exposure and washing tanks at the same time and administered water instead of AS, to control for the disturbance caused by handling and disruption of the water surface, respectively (Fig. 1).

Mate pairing and offspring rearing

Male zebrafish were paired with mature females derived from healthy stock in individual compartments of a flow-through system. Marble dishes were placed in the compartments to provide a substrate conducive to courtship and to protect embryos from cannibalism. Mate pairings were established in the late afternoon, for egg collection the following morning, approx. 2 h into the photoperiod. Following retrieval of the dishes, dead eggs were removed. Fertilised eggs were counted the following day, at 1-day post-fertilisation (DPF). One-DPF embryos from each parent were then divided into three sets: two sets of 21 were placed in 9-cm petri dishes with 50 ml water for assessment of larval AS response and a further 40 embryos in 12-cm plastic dishes, filled 3/4 with water, for rearing to adulthood. Larvae reared beyond 5-DPF were fed daily with commercial fry food ad libitum from 5-DPF. From 15-DPF, larvae were transferred to tanks (23.5 cm by 12.5 cm by 17.5 cm) on a flow-through system with water heated to 26 °C and reared for a further 25 days. From approx. 40-DPF, siblings were transferred into larger tanks at densities of 3–4 and fed commercial flake food and brine shrimp ad libitum.

Because it was not feasible to collect and rear all offspring at the same time, the experiment was

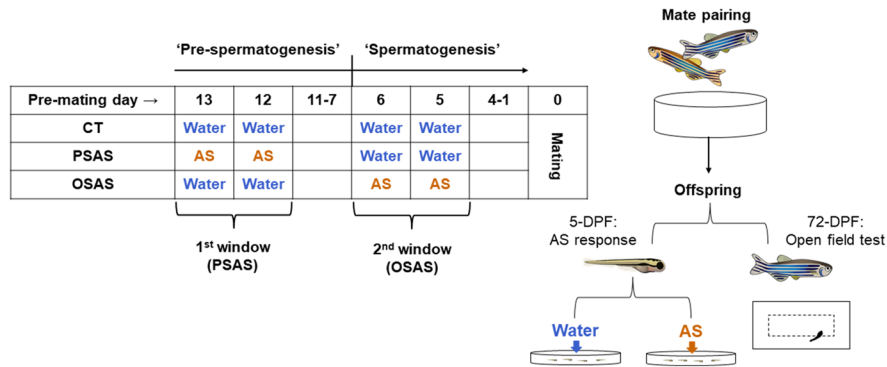

Fig. 1 Visual summary of experiment. Pre-spermatogenesis alarm substance (PSAS) fathers received 2×20-min alarm substance (AS) exposures during the first exposure window (13 and 12 days before mating), while onset-spermatogenesis alarm substance (OSAS) fathers were exposed during the second window (6 and 5 days before mating). Control (CT) ani-

mals and any animals which were not exposed during a given window were handled at the same time and administered water instead of AS. Offspring produced by pairing males with unexposed females were tested at 5-DPF for their response to AS and at 72-DPF in the open field test

carried out in four batches. Each batch comprised five adult males per experimental group and their subsequent offspring. Of the 60 mate pairings that were established throughout the experiment, 47 successfully mated, of which 41 produced broods of sufficient sizes to be used for testing (14 CT, 13 PSAS, and 14 OSAS broods in total). Depending on the batch, broods were used either for the larval AS response test, juvenile behavioural testing, or both. A total of 30 broods obtained from batches 1, 2, and 4 were used for the larval AS response test at 5-DPF (10 CT, 10 PSAS, and 10 OSAS). A total of 18 broods obtained from batches 1, 2, and 3 were used for the open field test at 72-DPF (6 CT, 7 PSAS, and 5 OSAS).

Larval AS response assay

At 5-DPF, zebrafish larvae have a functioning HPI axis which is capable of mediating behavioural and physiological responses to various stressors (Alsop and Vijayan 2008; Alderman and Bernier 2009; Yeh et al. 2013; Eachus et al. 2017). As a model behavioural stress response, we used thigmotaxis, the tendency of larvae to move towards the edge of the petri dish in response to a stressor, as demonstrated previously in response to AS (Ord et al. 2020) as well as anxiolytic compounds (Lundegaard et al. 2015).

At 5-DPF, offspring reared in 9-cm petri dishes was tested for thigmotaxis in response to AS. We

used a split-clutch design: from each brood produced by a father, two dishes of 21 larvae were used. Of these two dishes, one was administered AS (20 µl AS added to 50 ml water), while the other was administered water only as a control. Prior to exposure, the petri dishes were placed on an illuminated platform to maximise contrast between fish and background (to facilitate easier observation). During exposure, the petri dishes were video recorded from above using Panasonic HC-X920 digital camcorders.

The larval thigmotactic response was measured during three time intervals: the 5th, 10th, and 15th minute following exposure, respectively. To ensure the measure of thigmotaxis was representative of a given time interval, seven video stills were taken during each interval, spaced 10 s apart (e.g. for the 5th minute: from the 4-min mark and every 10 s up to and including the 5-min mark). In each still, the coordinates of all visible larvae were marked using ImageJ (Schneider et al. 2012). The Euclidean distance of each larva from the central point of its dish was calculated in mm, and a larva was classed as thigmotactic if it was more than 35 mm from the centre. The fraction of thigmotactic individuals was calculated for each still, and the mean fraction of thigmotactic individuals was calculated for the time interval (5th, 10th, or 15th minute). The mean fraction of thigmotactic individuals for a given time interval was the response variable in the subsequent statistical analysis.

For heatmap-based visualisation of larval densities, coordinates of individuals were normalised relative to the coordinates of the central point of the dish (relative X coordinate = $X_{\text{centre}} - X_{\text{larva}}$, relative Y coordinate = $Y_{\text{centre}} - Y_{\text{larva}}$), such that relative coordinates of all larval observations could be pooled for combined visualisation.

Open field testing of juveniles (72-DPF)

To ensure individuals tested were representative of the brood, behavioural testing was restricted to broods from which at least three offspring survived to 40-DPF. At least 1 week prior to open field testing, fish were separated from siblings and kept in isolated tanks to enable repeated trials of the same offspring, although individuals were still visible to each other through glass partitions. At 72-DPF, open field trials were carried out in opaque containers (17 cm \times 10 cm \times 10 cm) containing 500 ml water and covered by transparent Perspex lids to prevent escape by jumping. For each trial, the container was placed on a platform, illuminated from below to enhance contrast and maximise detection of the fish in video-tracking software (Nema et al. 2016). Fish were video recorded from above for 5 min following a 30-s acclimation period. Water was replaced between trials. Testing always took place in the afternoon, between 12.00 and 15.00 h, to reduce variation resulting from circadian activity levels or due to hunger. Each fish was subjected to 3 trials over 3 consecutive days. Two to five offspring from each qualifying brood were tested. Video recordings were analysed using automated tracking software (Viewpoint® ZebraLab). A tracking zone was defined, covering the central portion of the container (an area that excluded the outer 3 cm of the container, approximately), and the amount of time the fish was detected in this zone was recorded. Thigmotaxis was subsequently calculated as the percentage of the total trial duration (5 min) in which the fish was not detected in the central portion.

Statistical analyses and visualisation

All statistical analyses were carried out in ‘R’ 4.1.2 (R Core Team 2021). We used linear mixed effects models fit by restricted maximum likelihood (REML), using the lme4 package (Bates et al. 2015) because of the hierarchical structure

of the experimental design and the batch approach (plus parental animals within batches and treatment groups were housed together).

For the model of larval (5-DPF) offspring AS response, the response variable was the mean fraction of thigmotactic individuals during a given time interval. Offspring treatment (water or AS), paternal treatment (CT, PSAS, or OSAS), and time interval (5th, 10th, or 15th minute) were fixed effects, and interaction terms were included for all fixed effect combinations. Time interval was considered a discrete variable due to having only three levels. Batch, Father ID (nested within batch), and Dish ID (nested within Father ID) were included as random intercept terms.

For the model of juvenile (72-DPF) offspring thigmotaxis, the response variable was the % time spent in the peripheral zone during one of the three trials. Paternal treatment and trial day (categorical variable) were fixed effects as well as the interaction (Paternal \times Trial). Batch and Father ID were included as random effects as before, and ‘Offspring ID’ (nested within Father ID) was included as a further random effect due to the same individuals being observed across multiple days. Significance of fixed effect terms was evaluated using F -tests with type III sums of squares (effect of a term in the model while accounting for all other terms) and t -tests (effect of specific coefficients on the response variable) with Kenward-Roger approximation of degrees of freedom, derived using the `anova()` and `summary()` functions from the stats package in conjunction with the lmerTest (Kuznetsova et al. 2017) and pbkrtest (Hakekoh and Hojsgaard 2014) packages.

For specific inter-group comparisons (for specific time intervals following exposure to AS or for specific trials of the open field test), post-hoc pairwise comparisons of estimated marginal means were computed using the `emmeans()` function from the `emmeans` package (Lenth 2019).

All plots including the heatmaps of larval densities were produced using the `ggplot2` (Wickham 2011) and `ggh4x` (van den Brand 2021) packages.

Data were not recorded blindly; however, we chose measurement methods which did not rely on subjective judgement (coordinate marking for larval thigmotaxis and automated measurement for juvenile thigmotaxis, respectively).

A

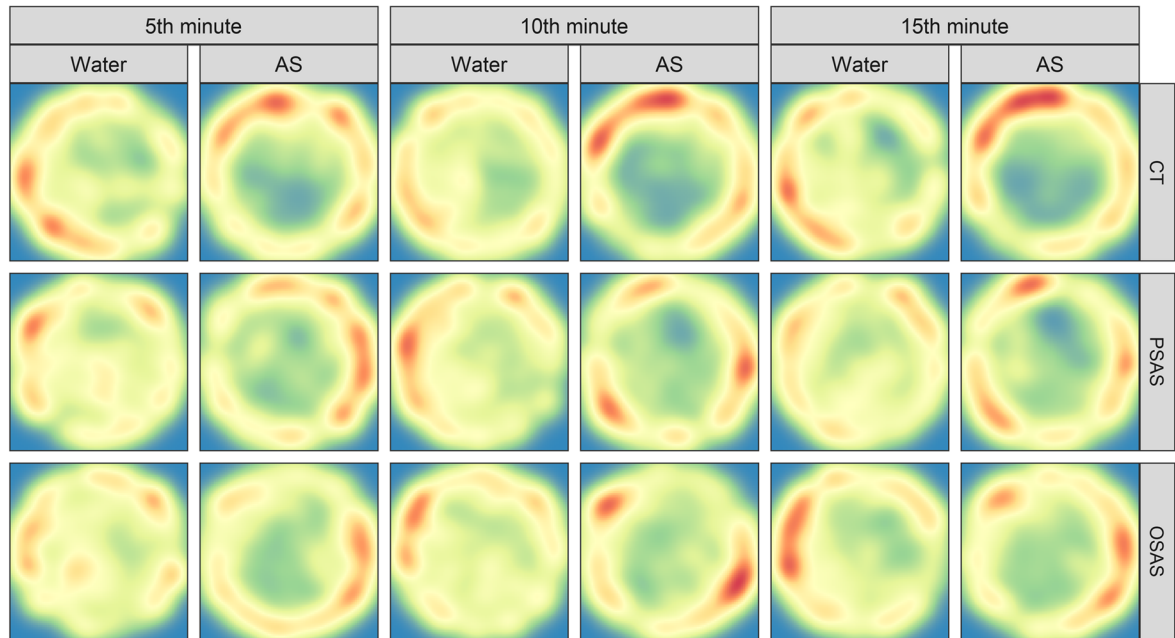

B

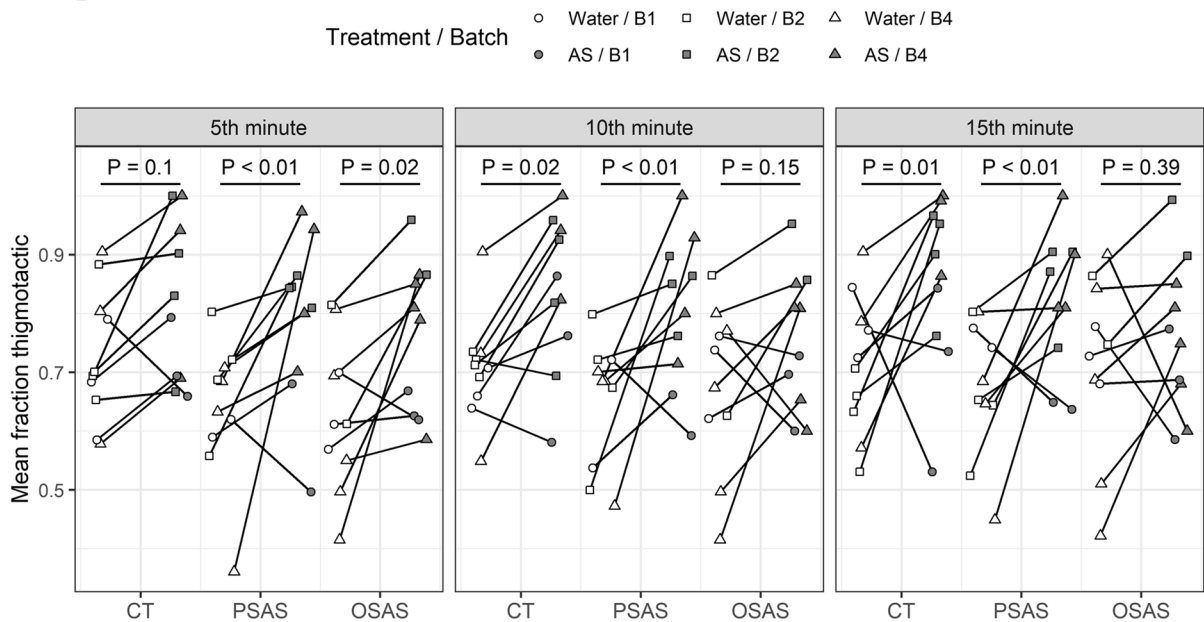

Results

Larval thigmotactic response to AS

The thigmotactic responses of larvae to AS were clearly visible from the distributions of combined observed locations (Fig. 2A). Mean fractions of

thigmotactic larvae were consistently higher for AS-treated dishes than water-treated dishes, largely regardless of time interval (5th, 10th, or 15th minute) and paternal treatment (Fig. 2B). However, not all dish pairs exhibited positive slopes, with some AS-treated dishes showing lower thigmotaxis than the water-treated dish from the same pair,

◀**Fig. 2** Alarm substance (AS)-induced thigmotaxis (edge preference behaviour) in 5-DPF larval zebrafish. **A** Heatmaps of observed positions of zebrafish larvae in 9-cm petri dishes across different larval treatment groups (water and AS), paternal treatment groups (CT, control; PSAS, pre-spermatogenesis alarm substance; OSAS, onset-spermatogenesis alarm substance), and time intervals (5th, 10th, and 15th minute intervals). Brighter colours (yellow to red) indicate higher densities of larval observations. **B** Thigmotaxis of larvae from CT, PSAS, and OSAS fathers was measured at three separate time intervals during exposure to either water (white points) or AS (grey points). Thigmotaxis was calculated as the mean fraction of thigmotactic individuals (> 3.5 cm from the dish centre) out of up to 21 total animals in a given dish. Dishes deriving from the same father are connected by lines, while point shape represents experimental batch (B1, B2, and B4; exposures performed on the same day within each batch). Responses are presented separately for each time interval for ease of interpretation. $N=10$, 10, and 10 dish pairs (water and AS) for CT, OSAS, and PSAS, respectively. P -values are derived from pairwise comparisons of estimated marginal means

while other dish pairs showed no clear difference in thigmotaxis.

F -tests of the linear mixed model revealed a highly significant effect of larval AS treatment on larval thigmotaxis when accounting for all other variables ($F_{1,27}=18.1$, $P<0.001$). Paternal treatment had no significant effect ($F_{2,25,3}=1.41$, $P=0.26$) and neither did the interaction of larval and paternal treatment ($F_{2,27}=0.48$, $P=0.62$). There was a significant effect of time interval ($F_{2,108}=3.56$, $P=0.03$), but no significant interactions between time interval and either of the other variables.

When examining the effects of individual coefficients in the model (Table S1), there was a significant interaction between the paternal OSAS treatment and the 15-min time interval ($t_{108}=2.27$, $P<0.01$), reflecting a visible increase in thigmotaxis in water-exposed OSAS larvae in the 15th minute compared to the same offspring in the 5th minute. There was also a significant three-way interaction between paternal OSAS, larval AS treatment, and the 15th minute time interval ($t_{108}=2.64$, $P<0.01$), reflecting a lack of discernible difference in thigmotaxis between water- and AS-treated OSAS larvae in the 15th minute, compared to a highly prominent difference between water- and AS-treated CT larvae.

Pairwise comparisons of estimated marginal means for separate time intervals revealed a significant effect of larval AS on thigmotaxis during the 5th minute in PSAS ($t_{38,3}=2.94$, $P<0.01$) and

OSAS larvae ($t_{38,3}=2.53$, $P=0.02$), but not in CT larvae ($t_{38,3}=1.66$, $P=0.1$). In the 10th minute, the effect of larval AS on thigmotaxis was significant in CT ($t_{38,3}=2.43$, $P=0.02$) and PSAS ($t_{38,3}=2.92$, $P<0.01$), but not OSAS larvae ($t_{38,3}=1.46$, $P=0.15$). In the 15th minute, the effect of larval AS on thigmotaxis was significant in CT ($t_{38,3}=2.61$, $P=0.01$) and PSAS ($t_{38,3}=2.78$, $P<0.01$), but not OSAS larvae ($t_{38,3}=0.87$, $P=0.39$).

Juvenile offspring thigmotaxis

When offspring were tested for thigmotaxis behaviour at 72-DPF, PSAS and OSAS offspring exhibited generally lower thigmotaxis than CT offspring across the three trials, although this was more apparent in trials 1 and 3 than in trial 2 (Fig. 3). F -tests of mixed model terms showed the effect of paternal treatment to be significant ($F_{2,13,8}=6.93$, $P<0.01$). There was also a significant effect of trial day ($F_{2,114}=27.7$, $P<0.001$) but no significant interaction between paternal treatment and trial day ($F_{4,112}=1.19$, $P=0.32$), reflecting reductions in thigmotaxis in the 2nd and 3rd trials that were common to all treatment groups.

Post-hoc pairwise comparisons of estimated marginal means showed that compared to CT, PSAS thigmotaxis was not significantly different in trials 1 ($t_{35}=1.9$, $P=0.12$) or 2 ($t_{35}=1.52$, $P=0.24$), but was significantly reduced in trial 3 ($t_{35}=3.6$, $P<0.01$). OSAS thigmotaxis was not significantly different from CT in trial 1 ($t_{37}=2.05$, $P=0.09$), but was significantly reduced in trials 2 ($t_{37}=2.48$, $P=0.03$) and 3 ($t_{37}=2.71$, $P=0.02$).

Discussion

We tested whether larval response to AS exposure and juvenile thigmotaxis were affected by paternal stress timed either before (PSAS) or during the onset of spermatogenesis (OSAS). We found no clear effect of either paternal treatment on the larval response to AS; however, we did observe a significant reduction in juvenile thigmotaxis which did not appear to depend on the window of paternal stress exposure.

By adopting a paired experimental design in which broods of offspring were divided and exposed either to AS or water as a control, we were able to derive a reaction norm for each brood in the form of the larval

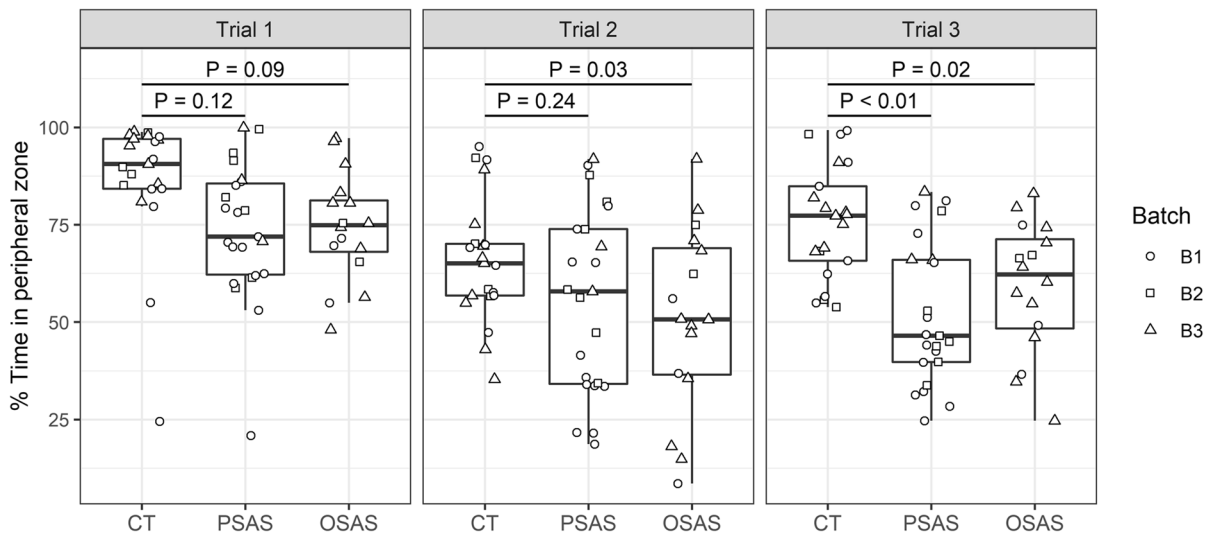

Fig. 3 Behaviour of juvenile offspring. Juvenile (72-DPF) offspring from CT (control), PSAS (pre-spermatogenesis alarm substance), and OSAS (onset-spermatogenesis alarm substance) fathers were assessed for thigmotaxis in 5-min open field tests repeated for each individual over 3 consecutive days (trials). Thigmotaxis was calculated as the % of the test duration in which the individual was detected exclusively in the peripheral 3 cm of the test chamber. Each point repre-

sents a measurement from one individual, while point shape represents experimental batch (B1, B2, and B3; individuals observed on the same days within each batch). $N(n)=6(21)$, $7(23)$, and $5(16)$ for CT, PSAS, and OSAS respectively, where N is the number of broods (i.e. fathers) represented and (n) is the total number of offspring tested. P -values are derived from pairwise comparisons of estimated marginal means

thigmotactic response to alarm substance. We found that most of the broods exhibited a positive slope during each of the time intervals examined. However, the steepness of this slope varied markedly across broods; not all AS-treated dishes had higher thigmotaxis, and some even had markedly lower thigmotaxis than their water-treated counterparts. This suggests that thigmotactic behaviour both at baseline and under stress conditions vary stochastically and that other sources of variation (e.g. genetic) may mask any effect of paternal environment. Indeed, we failed to detect an overall significant interaction between paternal treatment and larval AS exposure, suggesting that paternal treatment did not affect the larval thigmotactic response. However, there appeared to be a subtle, time-dependent effect of the OSAS treatment: in CT larvae, the response was strongest in the 15th minute, while the response of OSAS larvae was strongest in the 5th minute and subsequently waned. However, this seemed to be at least partly driven by variation in thigmotaxis in the water-exposed OSAS larvae of this group, which was increased during the final time interval. The differences in response to AS between CT and OSAS

larvae may therefore have resulted simply from stochastic variation in thigmotaxis.

We found a clear effect of paternal stress on the behaviour of offspring later in development, as seen by the reduced thigmotactic behaviour in juveniles of both PSAS and OSAS groups. Although thigmotaxis also varied across trial, which may be explained by habituation, the general trend was towards reduced thigmotaxis in the paternal stress groups. Although the significant effect of paternal stress appeared to be driven largely by the OSAS offspring, PSAS offspring thigmotaxis was nevertheless markedly lower in trials 1 and 3, suggesting similar effects of the two paternal stress treatments despite the different stages of differentiation targeted by them. This suggests that there are multiple alternative pathways of spermatogenic disruption which may produce similar endpoints in the offspring. Indeed, the effect of the PSAS treatment suggests that epigenetic alterations are proliferated during mitosis of spermatogonia (Leal et al. 2009). If epigenetic changes occur in undifferentiated spermatogonia including the stem cell candidates (those that do not differentiate but instead give rise to new undifferentiated spermatogonia) (Nóbrega et al.

2010), then they may persist into several subsequent spermatogenic cycles.

Reduced thigmotaxis behaviour in juvenile offspring is suggestive of disruption to the hypothalamic-pituitary-interrenal (HPI) axis (Alderman and Bernier 2009). The HPI axis encompasses the set of neuroendocrine pathways governing the stress response of fish, involving the production of cortisol and regulation of behavioural patterns. Its disruption typically manifests in altered behaviour such as suppressed responses to a stressor or altered anxiety-like behaviour (Eachus et al. 2017). Our findings of altered offspring behaviour are reminiscent of observations from rodent models of paternal stress, which have extensively reported offspring behavioural phenotypes reflective of suppressed or otherwise disrupted hypothalamic–pituitary–adrenal axis (mammalian homologue of the HPI axis) activity (Rodgers et al. 2013; Gapp et al. 2014).

We concede that we cannot be certain that the (pre-)spermatogenic stages affected by each treatment were as predicted; although the pace of spermatogenesis has been characterised in detail (Leal et al. 2009), this pace could be variable between strains, individuals, or environmental conditions. Likewise, the mechanistic basis of the heritable effects of stress was not elucidated in the present study. In mammals, the final period of sperm maturation in the epididymis has been recently identified as a likely critical window when the environment can alter the molecular composition of semi-mature sperm, with RNA carried in extracellular vesicles posited to be a key mechanism (Sharma et al. 2018). Similarly, recent work in sticklebacks suggests that paternal effects can be mediated by changes to mature, stored sperm (Chen et al. 2021). However, as zebrafish have a continuous mode of sperm production with no obvious compartment for sperm storage (Leal et al. 2009), we consider it unlikely that the paternal effects we observed in the present study were the result of changes to stored sperm. Rather, our finding that brief exposures before or at the onset of the spermatogenic cycle can induce heritable alterations to the progeny suggests that altered phenotype may also result from molecular alterations to earlier stage germ cells (e.g. DNA methylation, histone modifications, RNA) (Champroux et al. 2018). Although there exists the possibility that paternal effects have an adaptive

basis, maladaptive paternal effects resulting from disruption to the regulation of germ cell maturation are arguably a more plausible explanation of our results. Theoretical work predicts that adaptive parental effects are likely to evolve only if the parental environment predicts the offspring environment (English et al. 2015), and therefore intergenerational effects in response to transient exposures to stress are unlikely to be adaptive.

Finally, we concede some uncertainties around the use of AS as a model stressor. Although we used an approximate concentration of AS that has been previously demonstrated to induce behavioural and physiological responses in adult and larval zebrafish (Eachus et al. 2017), it is unclear whether the concentration used is ‘ecologically relevant’ in that wild zebrafish would detect similar concentrations from a nearby injured conspecific. Furthermore, as we did not control the sex of individuals used to extract AS, we cannot rule out potential influences of donor sex as a potential source of batch effects (Rohr et al. 2002).

Although the possible mechanisms of germ cell alteration which may lead to paternal intergenerational effects remain to be investigated, our data suggest that only brief exposures to an ecologically relevant stressor may disrupt the zebrafish spermatogenic cycle enough to result in detectable intergenerational effects. Furthermore, the timing of the paternal stress relative to spermatogenesis does not appear to affect the likelihood of intergenerational effects. However, no clear intergenerational effect was detected until the juvenile stage. Further work is therefore needed to develop and test sensitive readouts, especially in larval offspring. The findings could have positive implications for the welfare of experimental animals as they imply that use of prolonged stress paradigms comprising multiple stressors is not required in a framework to study intergenerational effects.

Acknowledgements The authors are indebted to William Holt for advice on experimental design and fish spermatogenesis; Phil Young, Linsey Gregory, and Allison Blake for support with animal husbandry; and Helen Eachus for advice and assistance with experimental protocols and phenotyping methods. The larval and adult zebrafish graphics used in Figure 1 were produced by Lizzy Griffiths (<http://zebrafishart.blogspot.com/>).

Author contribution P.J.W., A.F., and J.O. developed the initial concept. J.O. designed experiments in consultation with P.J.W. and A.F. J.O. performed experimental procedures, data

collection, and data analysis and wrote the manuscript. P.J.W. provided detailed feedback on the manuscript. All authors approved the submitted manuscript.

Funding Open access funding provided by University of Bern. J.O. was supported by a University of Sheffield scholarship, and the work received funding from the University of Sheffield.

Data availability CSV files containing data generated in this study (larval thigmotaxis and juvenile thigmotaxis data) and an R script of the analyses are included as supplementary materials (supplementary files 2, 3, and 4, respectively).

Declarations

Ethics approval All animal work was carried out under a UK Home Office licence for the use of animals in scientific procedures (licence number 40/3704).

Competing interests The authors declare no competing interests.

Open Access This article is licensed under a Creative Commons Attribution 4.0 International License, which permits use, sharing, adaptation, distribution and reproduction in any medium or format, as long as you give appropriate credit to the original author(s) and the source, provide a link to the Creative Commons licence, and indicate if changes were made. The images or other third party material in this article are included in the article's Creative Commons licence, unless indicated otherwise in a credit line to the material. If material is not included in the article's Creative Commons licence and your intended use is not permitted by statutory regulation or exceeds the permitted use, you will need to obtain permission directly from the copyright holder. To view a copy of this licence, visit <http://creativecommons.org/licenses/by/4.0/>.

References

- Alderman SL, Bernier NJ (2009) Ontogeny of the corticotropin-releasing factor system in zebrafish. *Gen Comp Endocrinol* 164:61–69. <https://doi.org/10.1016/j.ygcen.2009.04.007>
- Alsop D, Vijayan MM (2008) Development of the corticosteroid stress axis and receptor expression in zebrafish. *AJP Regul Integr Comp Physiol* 294:R711–R719. <https://doi.org/10.1152/ajpregu.00671.2007>
- Bates D, Maechler M, Bolker B, Walker S (2015) Fitting linear mixed-effects models using lme4. *J Stat Softw* 67:1–48
- Carvan MJ, Kalluvila TA, Klingler RH et al (2017) Mercury-induced epigenetic transgenerational inheritance of abnormal neurobehavior is correlated with sperm epimutations in zebrafish. *PLoS ONE* 12:e0176155. <https://doi.org/10.1371/journal.pone.0176155>
- Champroux A, Cocquet J, Henry-Berger J et al (2018) A decade of exploring the mammalian sperm epigenome: paternal epigenetic and transgenerational inheritance. *Front Cell Dev Biol* 6:50
- Chen E, Zielinski C, Deno J et al (2021) The specificity of sperm-mediated paternal effects in threespine sticklebacks. *Behav Ecol Sociobiol* 75:1–11. <https://doi.org/10.1007/s00265-021-03001-8>
- Chen Q, Yan W, Duan E (2016) Epigenetic inheritance of acquired traits through sperm RNAs and sperm RNA modifications. *Nat Rev Genet* 17:733–743. <https://doi.org/10.1038/nrg.2016.106>
- Donkin I, Versteyhe S, Ingerslev LR et al (2016) Obesity and bariatric surgery drive epigenetic variation of spermatozoa in humans. *Cell Metab* 23:369–378. <https://doi.org/10.1016/j.cmet.2015.11.004>
- Eachus H, Bright C, Cunliffe VT et al (2017) Disrupted-in-Schizophrenia-1 is essential for normal hypothalamic-pituitary-interrenal (HPI) axis function. *Hum Mol Genet* 26:1992–2005. <https://doi.org/10.1093/hmg/ddx076>
- Egan RJ, Bergner CL, Hart PC et al (2009) Understanding behavioral and physiological phenotypes of stress and anxiety in zebrafish. *Behav Brain Res* 205:38–44. <https://doi.org/10.1016/j.bbr.2009.06.022>
- English S, Pen I, Shea N, Uller T (2015) The information value of non-genetic inheritance in plants and animals. *PLoS ONE* 10:e0116996. <https://doi.org/10.1371/journal.pone.0116996>
- Gapp K, Jawaid A, Sarkies P et al (2014) Implication of sperm RNAs in transgenerational inheritance of the effects of early trauma in mice. *Nat Neurosci* 17:667–669. <https://doi.org/10.1038/nn.3695>
- Gapp K, van Steenwyk G, Germain PL et al (2018) Alterations in sperm long RNA contribute to the epigenetic inheritance of the effects of postnatal trauma. *Mol Psychiatry* 1. <https://doi.org/10.1038/s41380-018-0271-6>
- Hakekoh U, Hojsgaard S (2014) A kenward-roger approximation and parametric bootstrap methods for tests in linear mixed models—the R package pbkrtest. *J Stat Softw* 59:1–30
- Klosin A, Casas E, Hidalgo-Carcedo C et al (2017) Transgenerational transmission of environmental information in *C. elegans*. *Science* 356:320–323. <https://doi.org/10.1126/science.aah6412>
- Kuznetsova A, Brockhoff PB, Christensen RHB (2017) lmerTest Package: tests in linear mixed effects models. *J Stat Softw* 82:1–26. <https://doi.org/10.18637/jss.v082.i13>
- Leal MC, Cardoso ER, Nóbrega RH et al (2009) Histological and stereological evaluation of zebrafish (*Danio rerio*) spermatogenesis with an emphasis on spermatogonial generations. *Biol Reprod* 81:177–187. <https://doi.org/10.1095/biolreprod.109.076299>
- Lenth R (2019) Emmeans: estimated marginal means. R package version 1.4.2 <https://cran.r-project.org/package=emmeans>
- Lundegaard PR, Anastasaki C, Grant NJ et al (2015) MEK inhibitors reverse cAMP-mediated anxiety in zebrafish. *Chem Biol* 22:1335–1346. <https://doi.org/10.1016/j.chembiol.2015.08.010>
- Macartney EL, Crean AJ, Bonduriansky R (2018) Epigenetic paternal effects as costly, condition-dependent traits. *Heredity* 121:248–256. <https://doi.org/10.1038/s41437-018-0096-8>
- Nema S, Hasan W, Bhargava A, Bhargava Y (2016) A novel method for automated tracking and quantification of adult

- zebrafish behaviour during anxiety. *J Neurosci Methods* 271:65–75. <https://doi.org/10.1016/j.jneumeth.2016.07.004>
- Nóbrega RH, Greebe CD, van de Kant H et al (2010) Spermatogonial stem cell niche and spermatogonial stem cell transplantation in zebrafish. *PLoS ONE* 5:1–16. <https://doi.org/10.1371/JOURNAL.PONE.0012808>
- Oakberg EF (1956) Duration of spermatogenesis in the mouse and timing of stages of the cycle of the seminiferous epithelium. *Am J Anat* 99:507–516. <https://doi.org/10.1002/aja.1000990307>
- Ord J, Heath PR, Fazeli A, Watt PJ (2020) Paternal effects in a wild-type zebrafish implicate a role of sperm-derived small RNAs. *Mol Ecol* 29:2722–2735. <https://doi.org/10.1111/mec.15505>
- R Core Team (2021) R: A language and environment for statistical computing. R Foundation for Statistical Computing, Vienna, Austria. URL <https://www.R-project.org/>
- Rodgers AB, Morgan CP, Bronson SL et al (2013) Paternal stress exposure alters sperm MicroRNA content and reprograms offspring HPA stress axis regulation. *J Neurosci* 33:9003–9012. <https://doi.org/10.1523/JNEUROSCI.0914-13.2013>
- Rodríguez Barreto D, Garcia de Leaniz C, Verspoor E et al (2019) DNA methylation changes in the sperm of captive-reared fish: a route to epigenetic introgression in wild populations. *Mol Biol Evol* 36:2205–2211. <https://doi.org/10.1093/molbev/msz135>
- Rohr JR, Madison DM, Sullivan AM (2002) Sex differences and seasonal trade-offs in response to injured and non-injured conspecifics in red-spotted newts, *Notophthalmus viridescens*. *Behav Ecol Sociobiol* 52:385–393. <https://doi.org/10.1007/s00265-002-0525-8>
- Schneider CA, Rasband WS, Eliceiri KW (2012) NIH image to ImageJ: 25 years of image analysis. *Nat Methods* 9:671–675
- Sellem E, Marthey S, Rau A et al (2020) A comprehensive overview of bull sperm-borne small non-coding RNAs and their diversity across breeds. *Epigenetics Chromatin* 13:19. <https://doi.org/10.1186/s13072-020-00340-0>
- Sharma U, Sun F, Conine CC et al (2018) Small RNAs are trafficked from the epididymis to developing mammalian sperm. *Dev Cell* 46:481–494.e6. <https://doi.org/10.1016/j.DEVCEL.2018.06.023>
- Stewart A, Gaikwad S, Kyzar E et al (2012) Modeling anxiety using adult zebrafish: a conceptual review. *Neuropharmacology* 62:135–143. <https://doi.org/10.1016/j.neuropharm.2011.07.037>
- Tovo-Neto A, Martinez ERM, Melo AG et al (2020) Cortisol directly stimulates spermatogonial differentiation, meiosis, and spermiogenesis in zebrafish (*Danio rerio*) testicular explants. *Biomolecules* 10. <https://doi.org/10.3390/BIOM10030429>
- van den Brand T (2021) ggh4x: Hacks for “ggplot2.” R Package, version 0.2.1 <https://cran.rstudio.com/web/packages/ggh4x/index>
- Wang SY, Lau K, Lai K-P et al (2016) Hypoxia causes transgenerational impairments in reproduction of fish. *Nat Commun* 7:12114. <https://doi.org/10.1038/ncomms12114>
- Watkins AJ, Sinclair KD (2014) Paternal low protein diet affects adult offspring cardiovascular and metabolic function in mice. *Am J Physiol - Heart Circ Physiol* 306:H1444–H1452. <https://doi.org/10.1152/ajpheart.00981.2013>
- Wickham H (2011) ggplot2. *Wiley interdisciplinary reviews: computational statistics* 3:180–185. <https://doi.org/10.1002/wics.147>
- Yeh CM, Glöck M, Ryu S (2013) An optimized whole-body cortisol quantification method for assessing stress levels in larval zebrafish. *PLoS ONE* 8:1–8. <https://doi.org/10.1371/journal.pone.0079406>
- Zajitschek S, Hotzy C, Zajitschek F, Immler S (2014) Short-term variation in sperm competition causes sperm-mediated epigenetic effects on early offspring performance in the zebrafish. *Proc Royal Soc B: Biol Sci* 281:20140422–20140422. <https://doi.org/10.1098/rspb.2014.0422>
- Zamudio NM, Chong S, O’Bryan MK (2008) Epigenetic regulation in male germ cells. *Reproduction* 136:131–146. <https://doi.org/10.1530/rep-07-0576>

Publisher’s note Springer Nature remains neutral with regard to jurisdictional claims in published maps and institutional affiliations.